

Manufacturing plants
for prestressed concrete

Pressure Pipes

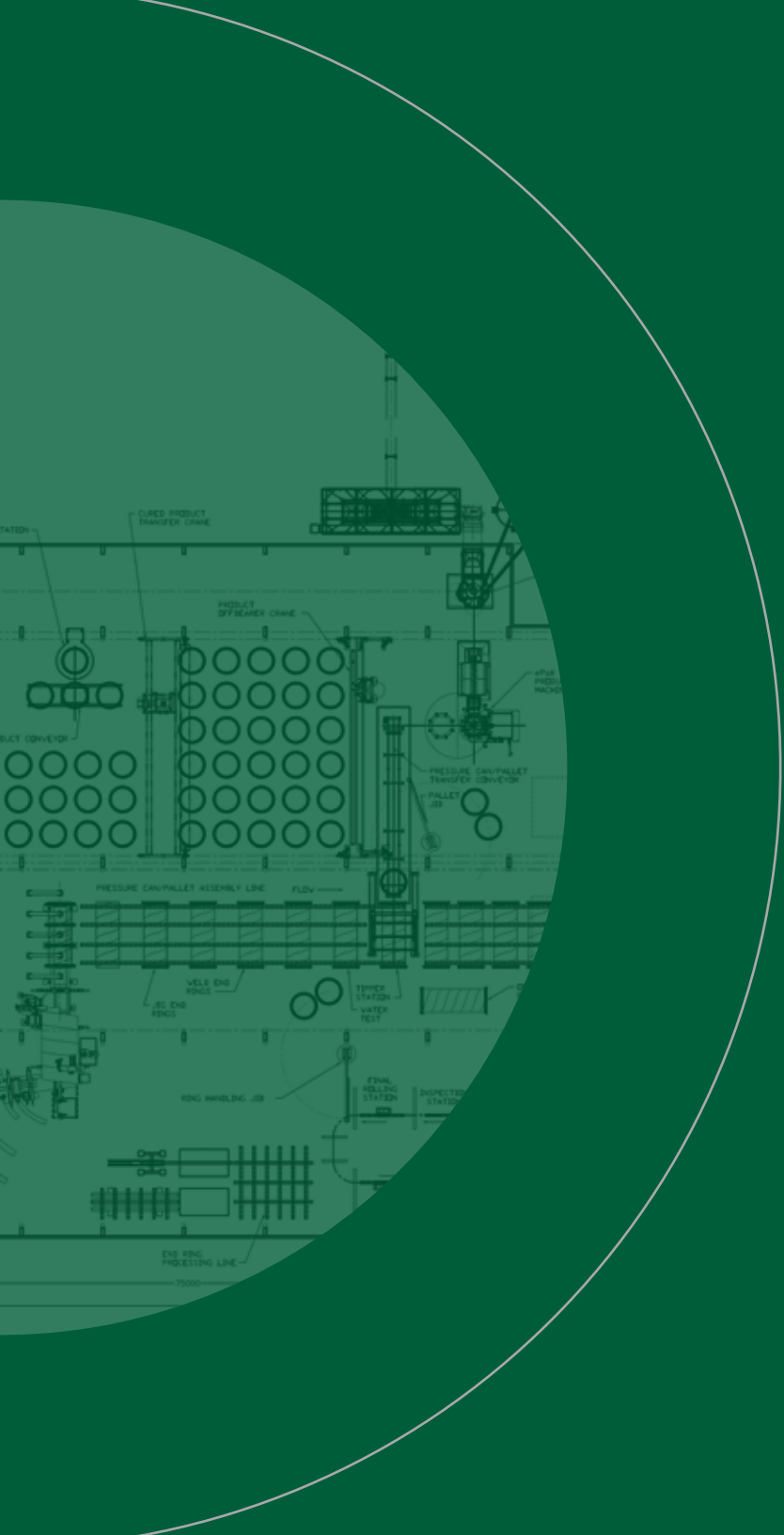

INNOVATIVE SOLUTIONS

Concrete Pressure Pipes

Concrete pressure pipes are used for water transmission lines where a substantial amount of water is transported by the use of pressure.

Concrete pressure pipes are designed and manufactured for specific projects according to design standards like e.g. AWWA C301-C303 or EN641/642. Depending on the specifications the concrete pressure pipes can be manufactured with or without steel cylinder inside and with or without prestressing wires.

Production Technologies

HawkeyePedershaab offers the full range of production technologies and services for the manufacture of concrete pressure pipes, including:

- Steel cylinder machines for making steel pipes when these are specified in the project.
- Machines for casting the concrete core - with a selection of different compaction technologies to optimise the production flow in each project.
- Prestressing machines for circumferential winding and tensioning of the pipes with steel wires.
- Coating machines for casting the concrete protection layer for the prestress wires.

In addition to this we offer a large range of curing, handling and testing solutions to optimise the flow of production.

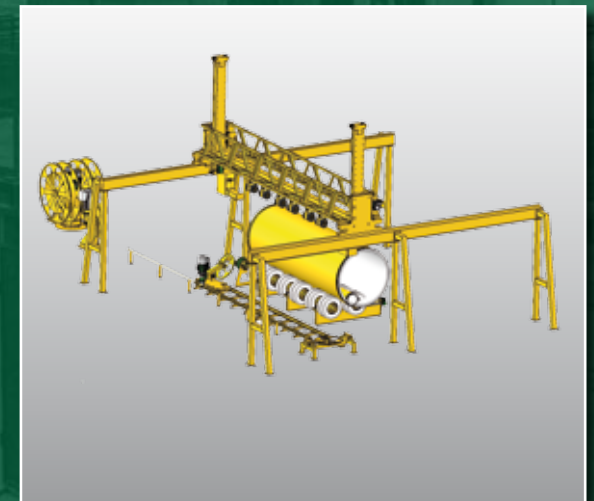
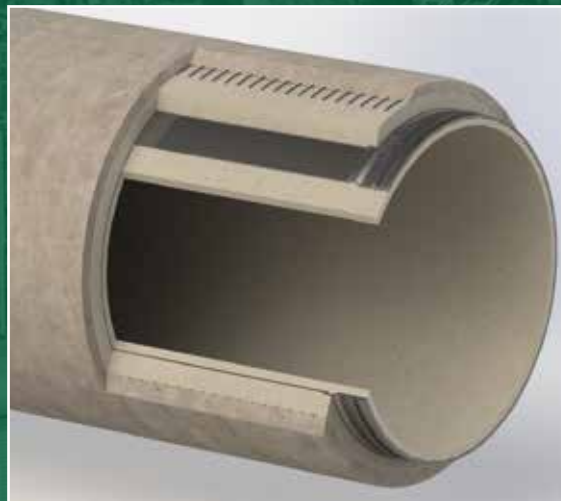
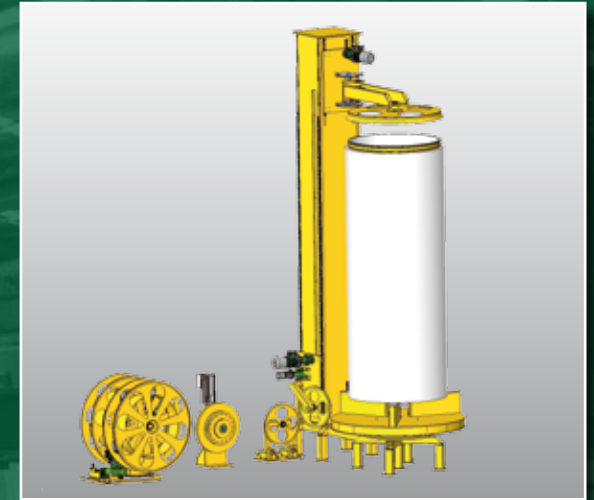
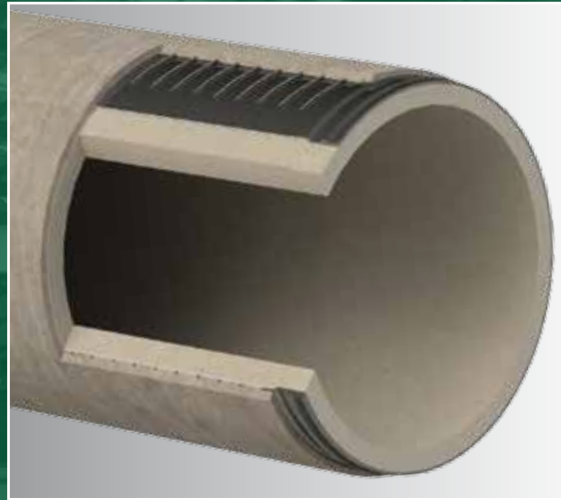

Turnkey Projects

Our services extend beyond the supply of equipment. We offer to take part in a project from the early stage starting with plant design, so the right choices are made for having an efficient production plant. In connection with this we make site and factory layout drawings which are an important tool in the plant design stage.

We also assist in making specifications for other plant equipment such as concrete batching and mixing plant, overhead cranes, welding equipment, etc. We even offer to supply everything directly, so you only need to have one single supplier of all these important items.

To manage the whole project we have a professional project management department who are used to handle turnkey projects all over the world. They will deal with everything from product specifications, delivery schedules, installation of equipment, and all financial and logistic issues. This way the entire procurement process for the production plant is streamlined.

Finally, to execute everything we employ experienced technicians who are used to work around the world to install our equipment. They will do this together with your own operators so they at the same time receive the training necessary to take over the operation when the installation and commissioning period is completed.



HawkeyePedershaab is the world leader in providing innovative solutions to manufacturers of concrete products for the infrastructural industry. From stand-alone machines to fully automated plants incorporating the latest in manufacturing technology, robotics, and control technology, HawkeyePedershaab furnishes a total family of solutions.

Leading with Creative Technology

We work hard to be the first to put new technology in your plant. We were the first to build automatic factories. The first to build rotary three-station pipe and manhole machines. The first to use rising core vibration technology with Compactor Rotor System. The first to build electronic, gearless drive packerhead machines. Our goal is simple – to create innovative and appropriate technology so our users can manufacture the highest quality product with the least possible cost and complication.

Global Experience + Local Presence

As a successful multinational organization, our people are our unique strength and your unique asset. With operations and activities on which the sun never sets, we enjoy more associates in more parts of the world than any other manufacturer of concrete production machinery. Dedicated professionals bring global awareness and capability to every phase of our business. Wherever on the planet you may be located, our peoples' intelligence, experience, and know-how will provide the immediate response and innovative solutions that you have come to expect from Hawkeye-Pedershaab.

Hawkeye Pedershaab
Concrete Technologies Worldwide™

North America, South America, Asia
506 S. Wapello Street
Mediapolis, Iowa 52637 - USA
Phone +1 (319) 394-3197
Telefax +1 (319) 394-3977

Europe, CIS, Africa, Australia, Oceania
Saltumvej 25
9700 Brønderslev - Denmark
Phone +45 9645 4000
Telefax +45 9645 4040

info@hawkeyepedershaab.com
www.hawkeyepedershaab.com

